

EQUIPMENT PARAMETERS		
MODEL	PCX-6F(SUV)	
Cars	10	
DIMENSIONS	L(mm)	<5300
	W(mm)	<1900
	H(mm)	<1950
	Weight(Kg)	<2500
DRIVEN	DRIVEN	Chain
	Motor(Kw)	9.2
	Speed (m/min)	4-6
POWER SUPPLY	AC, 3phase 5line	
OPERATION	TOUCH SCREEN/BUTTON/CARD	
SAFETY	Photoelectric switch	
PARKING	FORWARD ENTRY, BACKWARD EXIT	

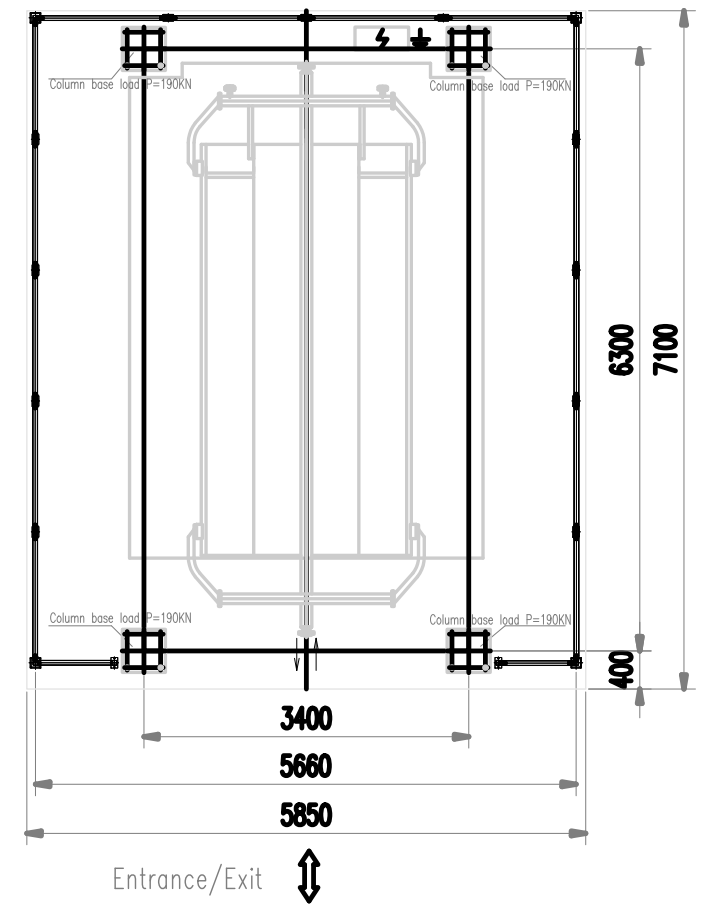
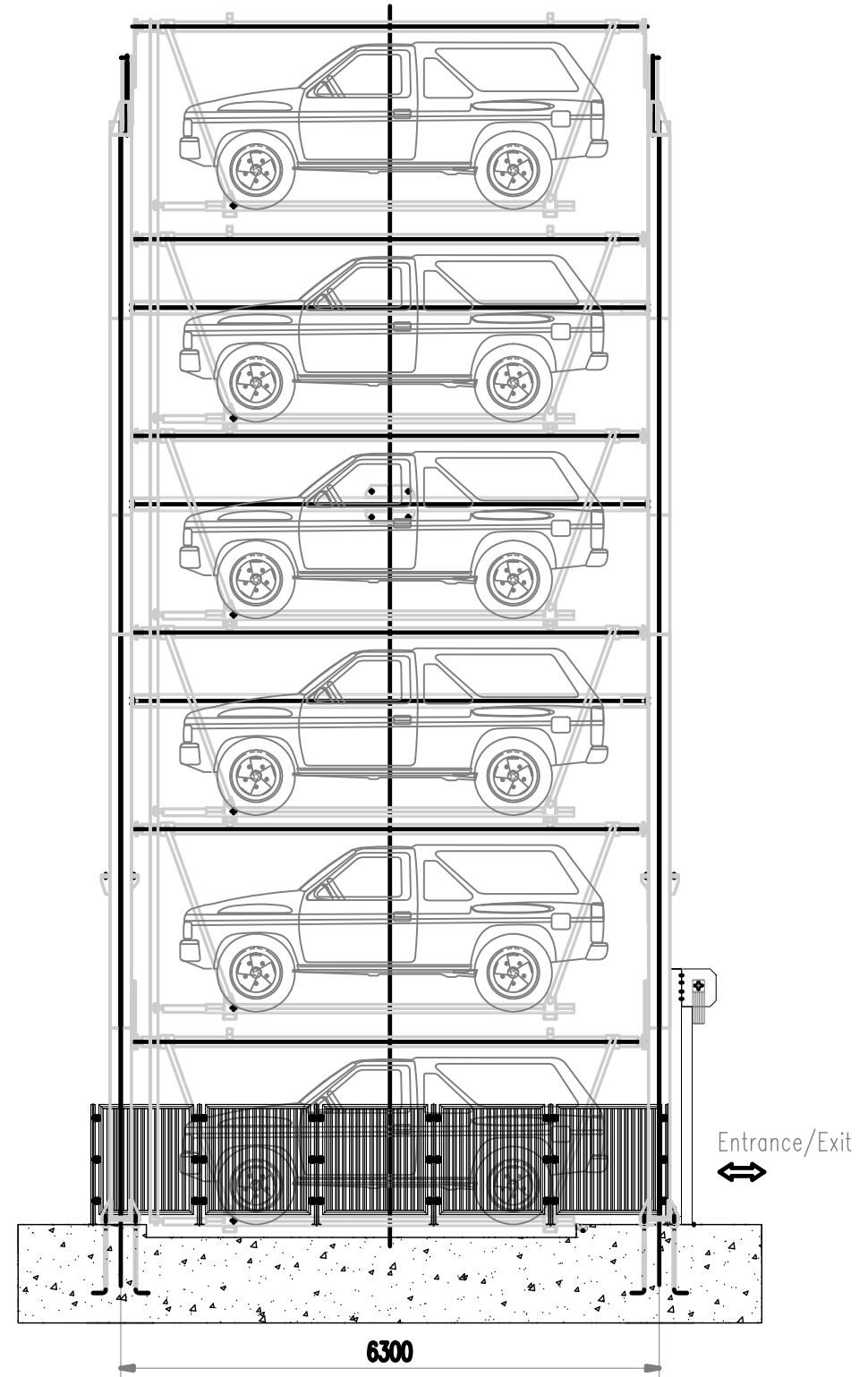
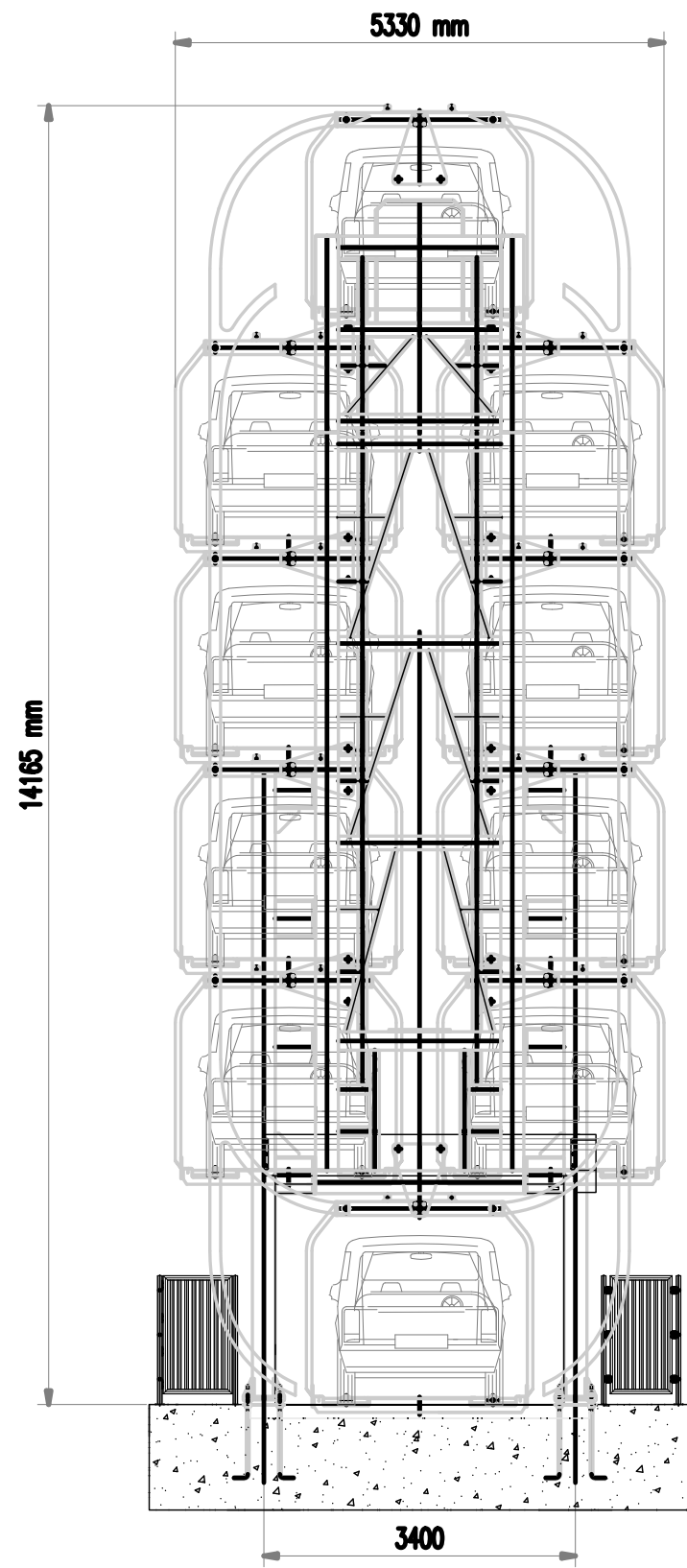

标记	张数	更改文件号	签字	日期
设计				
校对				
审核				
工艺				

PCX-6F-10SUV

Section

图样标记	重量	比例
共	页	第

TADA AUTO PARKING