

Model -1+1 puzzle parking with pit	
QTY	2×N-1(N is nuber of rows)
Lifting speed	Ground 4m/min Basement 3.5m/min
Sliding speed	8m/min
Lifting motor	2.2kw
Sliding motor	0.2kw
Power supply	3phae 5line/380V/50Hz

Notes:

1. If the customer requests to increase the civil clearance height by 300mm when parking the MPV OR SUV on the ground floor. This drawing shows a three-span device, and the number of spans can be increased or decreased according to the on-site space during actual planning.
2. This drawing shows a three-span device, and the number of spans can be increased or decreased according to the on-site space during actual planning.

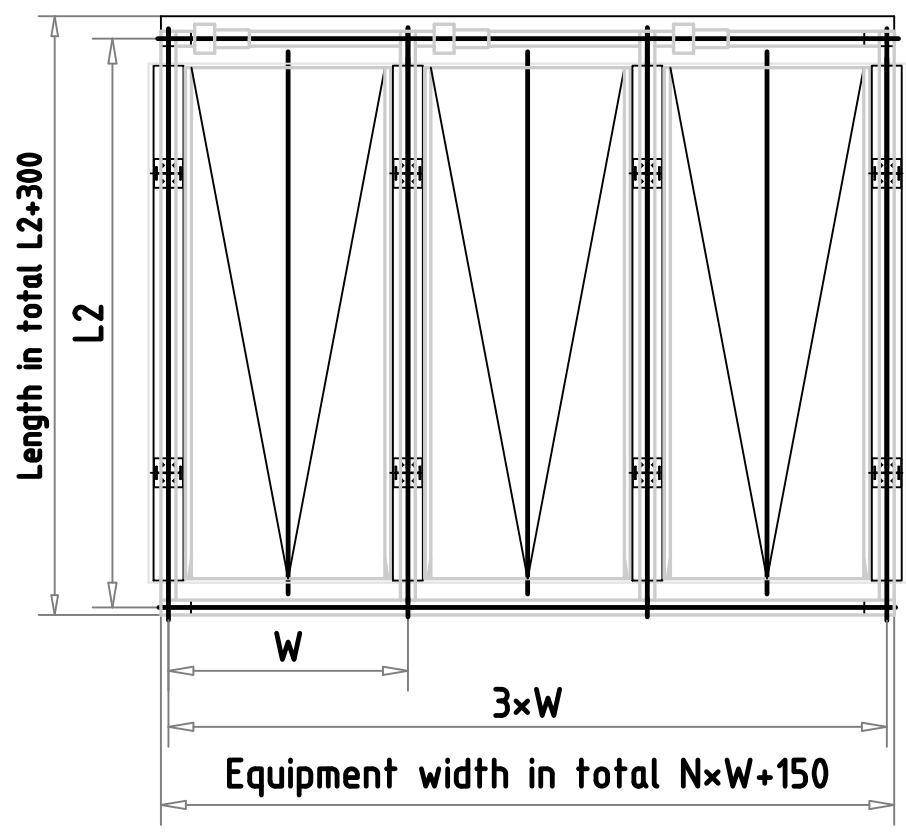
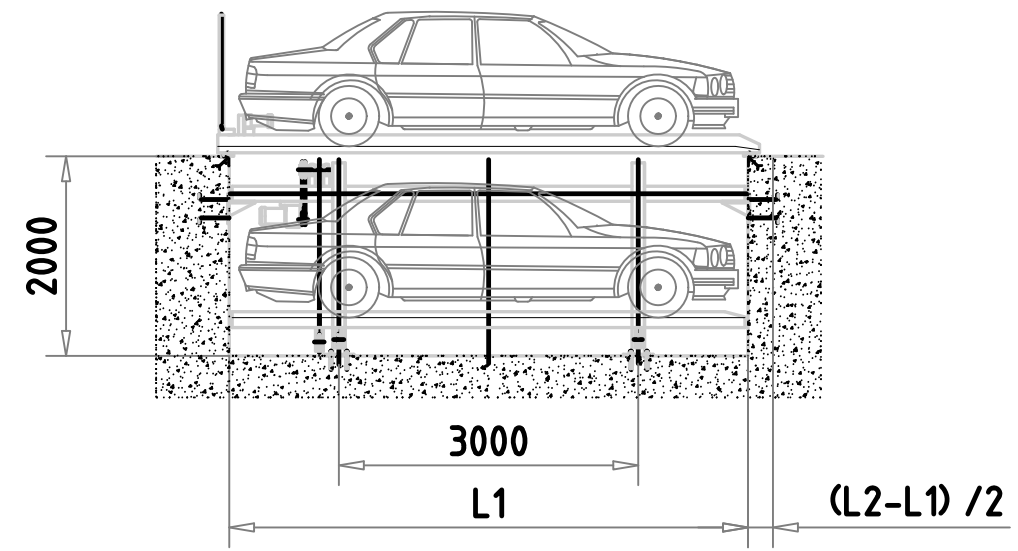
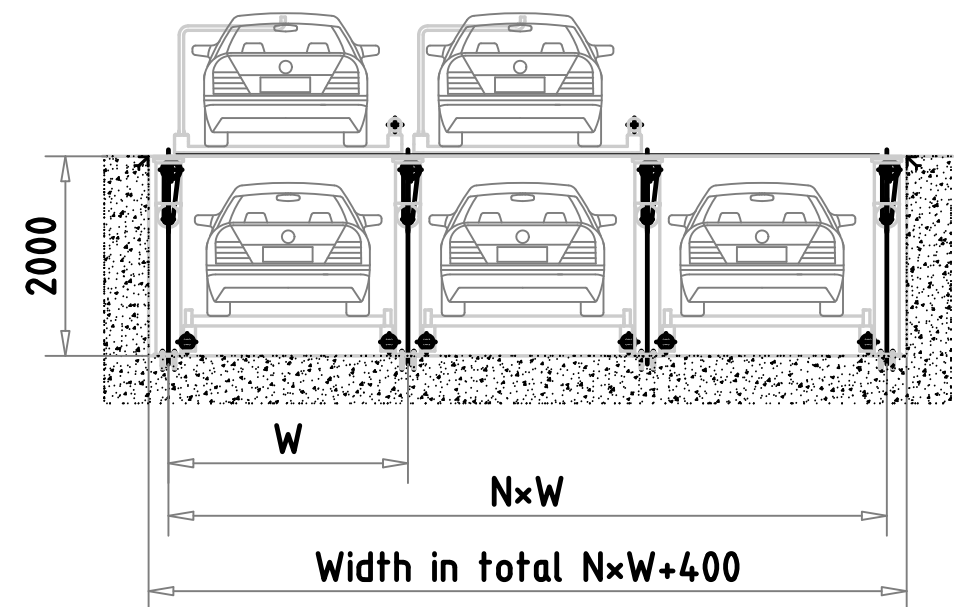

Main parameters and vehicles dimensions

Model	Dimensions (mm)			vehicles	
	L1	L2	W	Length×Width×Height (mm)	Weight (kg)
PSHxD/yZ-D1-3LT	5000	5500	2400	Ground: 5000×1850×1550	1700
				Pit: 4700×1800×1450	1500
PSHxD/yT-D1-3LT	5200	5700	2400 (2450) (2500)	Ground: 5300×1900×1550	2350
				Pit: 5000×1850×1550	1700